

Band Clamp Bag Housings

Commercial Grade

Designed with Snap Fit “V” Ring Bag

BCB Series Bag Housings are designed for a variety of industrial filtration applications where clean effluent is critical. Offered in Extended Area bag sizes to increase contaminant removal and provide longer bag life

Features

- ▶ 304 stainless steel construction, standard
- ▶ 316 stainless steel construction, optional
- ▶ Electropolished finish, standard
- ▶ 150 psi pressure rating
- ▶ Flow rates up to 200 GPM
- ▶ All filter housings hydrostatically tested
- ▶ Band clamp closure to simplify maintenance
- ▶ Internal parts are 304 stainless steel
- ▶ Drill in-place legs
- ▶ Patented Extended Area replacement bags available (approx. 30% more surface area vs. Std. bags)
- ▶ 1.5” FNPT or 2” FNPT connections available
- ▶ 316 stainless steel perforated basket, standard



BCB-1

BCB-2

Applications

- ▶ Paint
- ▶ Process Water
- ▶ Plating Solutions
- ▶ Coatings
- ▶ Industrial Waste Water Treatment
- ▶ Lubricants
- ▶ Solvents
- ▶ Hydraulic Fluids
- ▶ Cutting Fluids
- ▶ Ground Water Remediation



#1

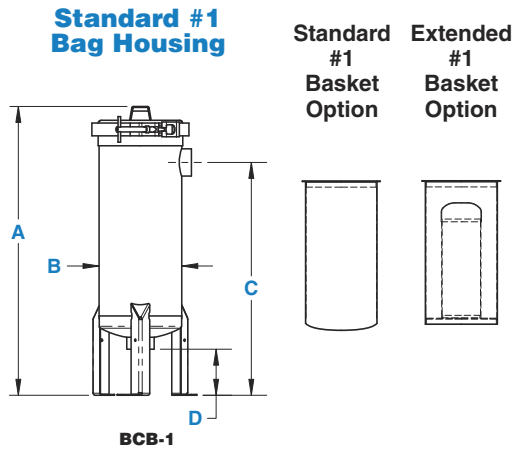

#2

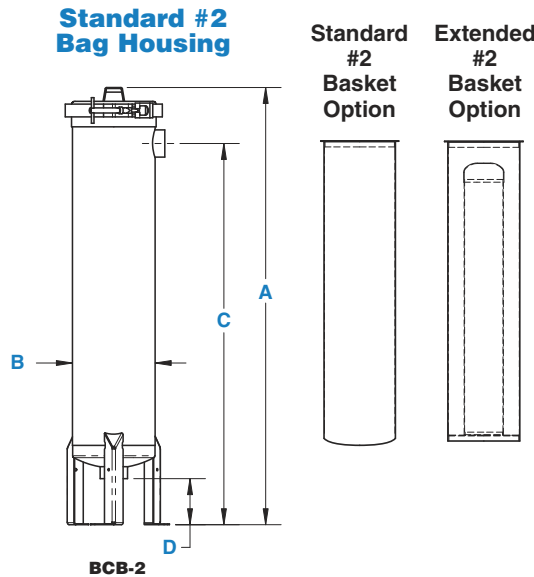

Bag Options



Standard #1
Standard #2
(shown)
Extended #1
Extended #2

Ordering Information

Standard #1 and #2 Bag Housings

Filter Model	Max Flow Rate*(GPM)	Max Flow Rate*(LPM)	Max Flow Rate*(M ³ /Hr)	A Height	B Diameter	C Inlet Height	D Outlet Height	I/O FNPT	Standard Bag Size
BCB-1-1.5-STD	100	341	20.4	28-1/4"	8"	22-3/4"	4-1/2"	1.5"	1 Std
BCB-1-2-STD	100	341	20.4	28-1/4"	8"	22-3/4"	4-1/2"	2"	1 Std
BCB-2-1.5-STD	200	757	45.4	42-3/4"	8"	37-1/4"	4-1/2"	1.5"	2 Std
BCB-2-2-STD	200	757	45.4	42-3/4"	8"	37-1/4"	4-1/2"	2"	2 Std

Extended #1 and #2 Bag Housings

Filter Model	Max Flow Rate*(GPM)	Max Flow Rate*(LPM)	Max Flow Rate*(M ³ /Hr)	A Height	B Diameter	C Inlet Height	D Outlet Height	I/O FNPT	Extended Bag Size
BCB-1-1.5-EXT	100	341	20.4	28-1/4"	8"	22-3/4"	4-1/2"	1.5"	1 Ext
BCB-1-2-EXT	100	341	20.4	28-1/4"	8"	22-3/4"	4-1/2"	2"	1 Ext
BCB-2-1.5-EXT	200	757	45.4	42-3/4"	8"	37-1/4"	4-1/2"	1.5"	2 Ext
BCB-2-2-EXT	200	757	45.4	42-3/4"	8"	37-1/4"	4-1/2"	2"	2 Ext

Flow rates shown above are for guidelines only. Actual flow rates are based on bag type, micron rating, viscosity, solids content and various other factors. For complete flow and pressure drop information please refer to your bag manufacturer guidelines.

Specifications

- ▶ **Finish** - Electropolished
- ▶ **Inlet/Outlet** - 1.5" FNPT or 2" FNPT
- ▶ **Construction** - 304 stainless steel, standard; 316 stainless steel, optional
- ▶ **Pressure** - Up to 150 psi (10.3 bar)
- ▶ **Temperature** - up to 250°F(121°C), housing only
- ▶ **Closure** - O-ring Housing Seal - Buna-N

Note: This publication is to be used as a guide. The data within has been obtained from many sources and is considered to be accurate. Harmsco does not assume liability for the accuracy and/or completeness of this data. Changes to the data can be made without notification. Temperature, Pressure, Flow Rates, Differential Pressures, Chemical Combinations and other unknown factors can affect performance in unknown ways. **Limited Warranty:** Harmsco warrants their products to be free of material and workmanship defects. Determination of suitability of Harmsco products for uses and applications contemplated by Buyer shall be the sole responsibility of Buyer. The end user/installer/buyer shall be liable for the product's performance and suitability regarding their specific intended applications. End users should perform their own tests to determine suitability for each application.



HARMSCO® Filtration Products

7169 49th Terrace North, Riviera Beach, FL 33407
(561) 848-9628 • Toll-free: (800) 327-3248 • E-mail: sales@harmsco.com

www.harmsco.com



Made in USA
5/26 Rev. 4