

# HARMSCO®

# INV

## Hurricane® Involute®

Industrial

### Up-Flow Filtration

A design so superior it's patented

Harmsco® Hurricane® Involute® filter housings provide unsurpassed performance. The Hurricane® technology' Cyclonic separation Removes heavy dense solids prior to cartridge filtration for extended filter life, increase dirt holding capacity and reduced operating costs Patented Involute design ensures uniform filter cartridge loading throughout the filter housing



Top View

### Features

- ▶ 304L stainless steel construction - standard
- ▶ Matte finish - standard
- ▶ 150 psi (10.3 bar) pressure rating
- ▶ Flow rates of up to 1,900 gpm
- ▶ All filter housings hydrostatically tested
- ▶ Accepts 40" L x 2.5" OD or 2.75" OD cartridges in DOE
- ▶ Two drains provided - inlet and outlet liquids
- ▶ Extensive choice of cartridge micron ratings and sizes
- ▶ Integral mounting legs, drill in place
- ▶ 316L Stainless Steel Sanitary, BSPT, (Optional)



Certified to NSF/ANSI/CAN Standard 61



Model: INV-72-8FL series

### Applications

- ▶ Cooling Tower Filtration
- ▶ Process Water Filtration
- ▶ Reverse Osmosis Pre-Filtration
- ▶ Utility Water
- ▶ Municipal Waste Water Treatment
- ▶ Ground Water Under Direct Influence (GWUDI)



**HARMSCO® Filtration Products**



Made in USA

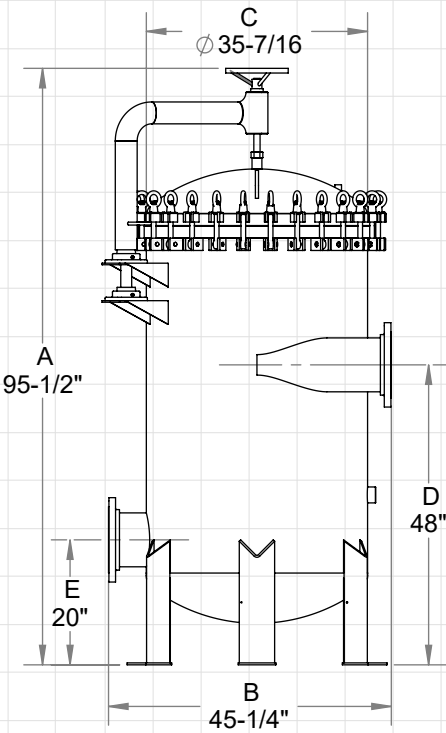

Certified to NSF/ANSI/CAN Standard 61

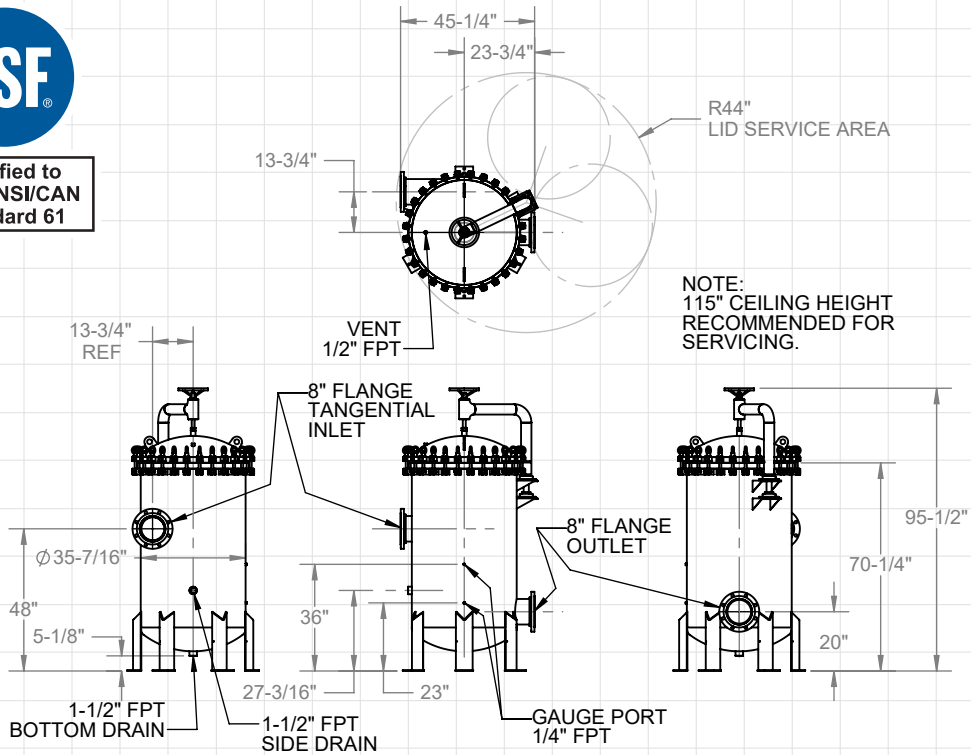

Filter Model	Max Flow Rate* (GPM)	Max Flow Rate* (LPM)	Max Flow Rate* (M <sup>3</sup> /Hr)	A	B	C	D	E	I/O Size	I/O Type	Drain Size
INV-72-8FL-DOE	1900	7192	431	95.5"	45.25"	35.44"	48"	20"	8"	FLANGE	1.5" FPT

\*Flow rates shown are for guidelines only. Actual flow rates are based on cartridge type, micron rating, viscosity, solids content and a number of other factors. For complete flow and pressure drop information please refer to your cartridge manufacturer guidelines.\*

## Specifications

### Cartridge Style

Harmsco® Involute® Cartridge Filter Housings are available with specific internal components which allow for the use of DOE end cap cartridges.

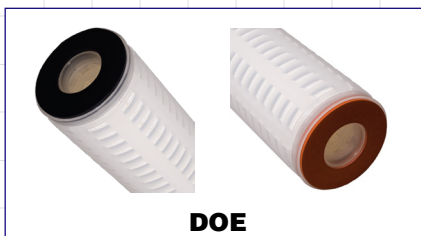

DOE

- ▶ **Finish** - Electropolish standard
- ▶ **Inlet/Outlet** - 8" Flange; Connections optional
- ▶ **Closure** - Swing Bolt with Buna-N o-ring; EPDM or Viton o-ring optional

### Pressure Drop

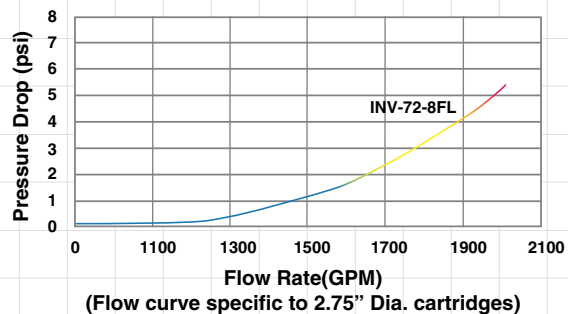

- ▶ **Pressure** - Up to 150 psi (10.3 bar) max
- ▶ **Construction** - 304L stainless steel standard; 316L stainless or Duplex steel optional
- ▶ **Temperature** - up to 250°F (121°C), housing only

**Note:** This publication is to be used as a guide. The data within has been obtained from many sources and is considered to be accurate. Harmsco does not assume liability for the accuracy and/or completeness of this data. Changes to the data can be made without notification. Temperature, Pressure, Flow Rates, Differential Pressures, Chemical Combinations and other unknown factors can affect performance in unknown ways. **Limited Warranty:** Harmsco warrants their products to be free of material and workmanship defects. Determination of suitability of Harmsco products for uses and applications contemplated by Buyer shall be the sole responsibility of Buyer. The end user/installer/buyer shall be liable for the product's performance and suitability regarding their specific intended applications. End users should perform their own tests to determine suitability for each application.



**HARMSCO® Filtration Products**

7169 49th Terrace North, Riviera Beach, FL 33407  
(561) 848-9628 • Toll-free: (800) 327-3248 • E-mail: sales@harmsco.com

[www.harmsco.com](http://www.harmsco.com)



Made in USA  
7/25 Rev. 2