

HARMSCO®

Multi Bag Housings

HMB-E

Municipal / Industrial

Designed with **Snap Fit “V” Ring Bag Seal** to prevent by-pass

HMB Series Bag Housings are designed for high flow, high contaminant removal

Features

- ▶ 304 stainless steel construction, standard
- ▶ 304 stainless steel perforated baskets, standard
- ▶ 150 PSI (10.3 bar) pressure rating
- ▶ Bead blast finish, standard
- ▶ Designed to accept standard #2 Snap Fit “V” Ring or steel ring bags
- ▶ Two gauge ports - inlet and outlet sides
- ▶ Assisted davit arm with eye-nut closure
- ▶ 316 stainless steel construction (Optional)



HMB-4E-FL

Applications

- ▶ Paint
- ▶ Process Water
- ▶ Plating Solutions
- ▶ Coatings
- ▶ Industrial Waste Water Treatment
- ▶ Lubricants
- ▶ Solvents
- ▶ Hydraulic Fluids
- ▶ Cutting Fluids
- ▶ Ground Water Remediation



HARMSCO® Filtration Products



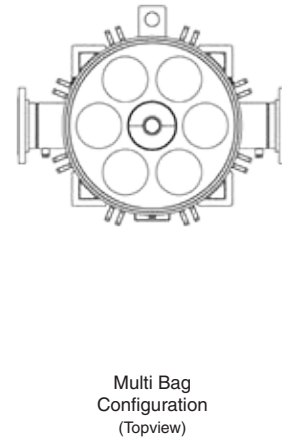
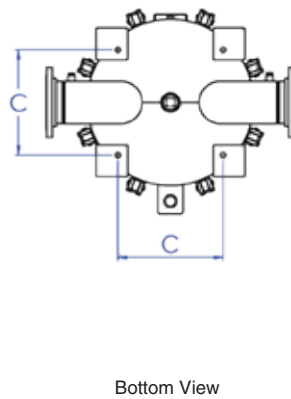
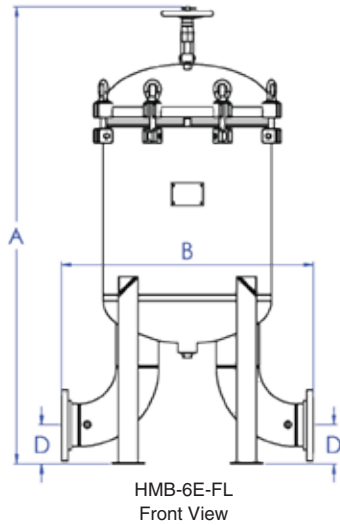

Ordering Information

| Filter Model | Max Recommended Flow Rate* | | | A Filter Height | B Width | C Mounting | D Inlet/Outlet | I/O Size | Drain | Bag Size | Basket Depth |
|--------------|----------------------------|-------|--------------------|--------------------|------------|---------------|-------------------|----------|---------|----------|--------------|
| | GPM | LPM | M ³ /Hr | | | | | | | | |
| HMB-4E-FL | 600 | 2,271 | 136 | 63" | 30" | 13-5/8" | 5-1/8" | 4" FL | 2" FNPT | #2 | 30" |
| HMB-6E-FL | 900 | 3,407 | 204 | 70-3/4" | 39" | 16-1/2" | 6" | 6" FL | 2" FNPT | #2 | 30" |
| HMB-8E-FL | 1,200 | 4,542 | 273 | 71-3/4" | 40" | 19-3/4" | 6" | 6" FL | 2" FNPT | #2 | 30" |
| HMB-12E-FL | 1,800 | 6,814 | 409 | 81" | 50" | 25-1/2" | 7-1/4" | 8" FL | 2" FNPT | #2 | 30" |

*Flow rates shown above are for guidelines only. Actual flow rates are based on bag type, micron rating, viscosity, solids content and various other factors. For complete flow and pressure drop information please refer to your bag manufacturer guidelines.

Specifications

- ▶ **Inlet/Outlet** - flange connections
- ▶ **Construction** - 304 stainless steel
- ▶ **Closure** - O-ring housing seal with swing bolt closure
- ▶ **Finish** - bead blast
- ▶ **Pressure** - up to 150 PSI (10.3 bar) max
- ▶ **Temperature** - up to 250°F (121°C); filter housing only

Snap Fit "V" Style Filter Bag



Pressure Drop

Based on 4", 6" and 8" inlet/outlet housings, without bags.

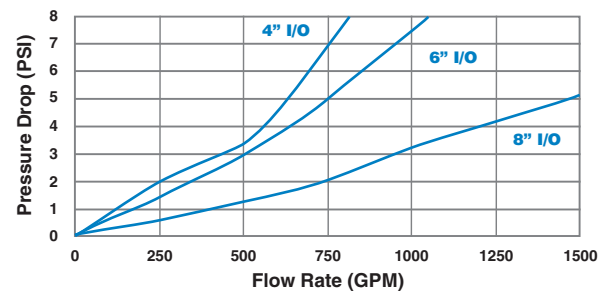

Note: This publication is to be used as a guide. The data within has been obtained from many sources and is considered to be accurate. Harmsco does not assume liability for the accuracy and/or completeness of this data. Changes to the data can be made without notification. Temperature, Pressure, Flow Rates, Differential Pressures, Chemical Combinations and other unknown factors can affect performance in unknown ways. **Limited Warranty:** Harmsco warrants their products to be free of material and workmanship defects. Determination of suitability of Harmsco products for uses and applications contemplated by Buyer shall be the sole responsibility of Buyer. The end user/installer/buyer shall be liable for the product's performance and suitability regarding their specific intended applications. End users should perform their own tests to determine suitability for each application.



HARMSCO® Filtration Products

7169 49th Terrace North, Riviera Beach, FL 33407
(561) 848-9628 • Toll-free: (800) 327-3248 • E-mail: sales@harmsco.com

www.harmsco.com

